

SPO5R2SDL

COMBI STEAMER WITH STEAMART TECHNOLOGY

5 trays GN1/1



NEW THERMOFUNNEL CAVITY

The careful design of the **new cavity**, with a **parabola-shaped** back, and new **deflector geometry** improves air distribution and ensures homogeneous heating of all types of food. This produces uniform cooking and excellent results with a reduction in cooking times and energy consumption.

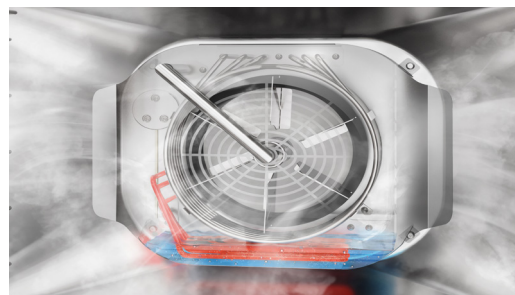

STEAMART TECHNOLOGY

Allows you to generate **saturated steam** by boiling directly in the oven without the need for an external boiler, **in a very short time and even at low temperatures** (starting from 30°C to assist proving). The optimal solution for delicate cooking using 100% steam, for example when cooking vegetables and fish, while maintaining the properties of the food unaltered and with minimal weight loss.



PRODUCT FEATURES

- Functional design, robust stainless steel construction
- Full stainless steel oven cavity
- Digital canvas 7" display that allows customisation of operating modes. Easy to use and allows any chef to achieve the best results.
- Multi-point core probe (4 temperature points)
- Capacity to do multi-level cooking for complex menus that require different foods to be cooked at the same time.
- Excellent internal visibility due to the large glass and powerful inner LED lights
- Triple glass door, with internal glass removable for cleaning
- USB port: located on the side door, conveniently positioned for instant updates and loading new recipes.
- 24 months parts and labour warranty

WASHART SYSTEM

Distributes water and detergent uniformly inside the cavity, ensuring cleaning and drying in a very short time and with reduced energy and water consumption. Four automatic wash cycles are available and one rinse cycle.



COMBINED

Combine convection mode power and temperatures with direct steam injection. Minimum weight loss during cooking and perfect food regeneration.



VAPOUR

The use of SteamArt saturated steam optimizes efficiency, guarantees uniform cooking and preserves all the nutrients in the food, enhancing its colours and flavours.

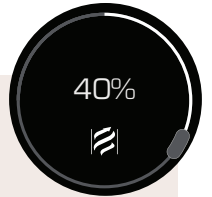

GRILL

Controlling the vents allows you to adjust the humidity in the cooking cavity to obtain the ideal environment in which to grill food.

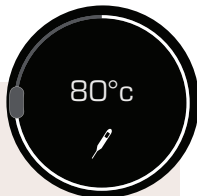

NIGHT

Low temperature cooking optimises times and guarantees that the dish is cooked perfectly and delicately with minimum weight loss and low energy consumption.

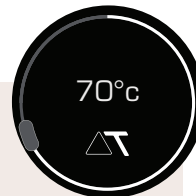

ΔT° SYSTEM

The ΔT° function, combined with the precise temperature control provided by the multi-point probe, guarantees excellent and repeatable results.

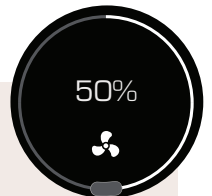

DRY ENVIRONMENT

Uniform cooking thanks to the air circulation system that allows you to cook food with the same results at every level, even when the oven is full.



SPO5R2SDL

COMBI STEAMER WITH STEAMART TECHNOLOGY

5 trays GN1/1

TECHNICAL SPECIFICATIONS

Oven material	Stainless steel	Components cooling system	Yes
External dimensions (WxDxH)	790 x 839 x 630mm	Timer type	Electronic timer
Cavity material	Stainless steel	Temperature range	30 - 270°C
Number of shelves	5 with GN1/1	End cooking signal	Yes
Tray frame support	Stainless steel AISI 304 Chromed wire Double format	Manual reset safety thermostat	Yes
Shelves distance	70mm	Removable deflector	Yes
Door opening	Lateral	Detergent type	Liquid
Handle type	New ergonomics	Lighting	1 LED
Openable glass	Yes	Light power	3.6 W
Fan type and number	1 counter rotating fan with time direction reversal	USB port	Yes
Pulse fan	2 counter rotating fan with time direction reversal	Water load pipe	Yes
Engine power	200W	Power cable length	170cm
Max standard speed motor rpm	2,000rpm	Back panel	Galvanized
Low speed rpm	1,425 rpm	IPX protection	End cooking with auto- matic shutdown
Water injection on the fan	Yes	Electrical connection	400V 3N~/17.5 A/ 8,0 kW/50Hz
Humidification levels	Automatic and progressive percentage	Net weight	92 kg
Open boiler	Yes		

TECHNICAL DRAWING

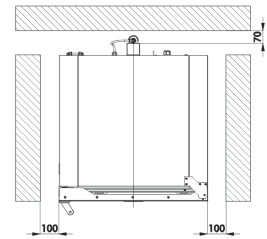
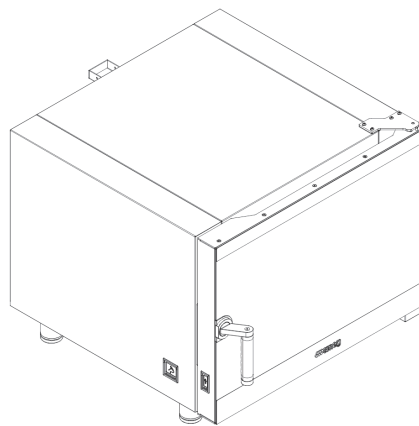
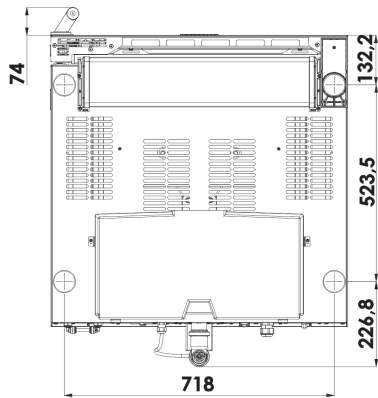
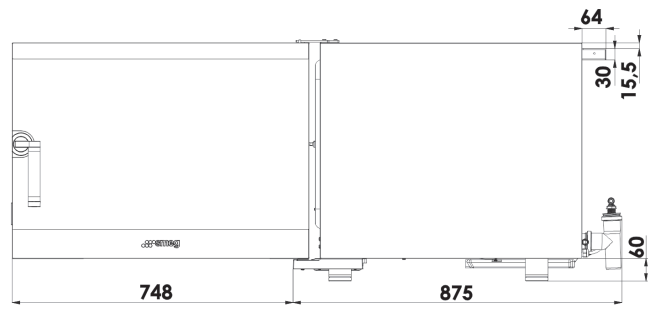
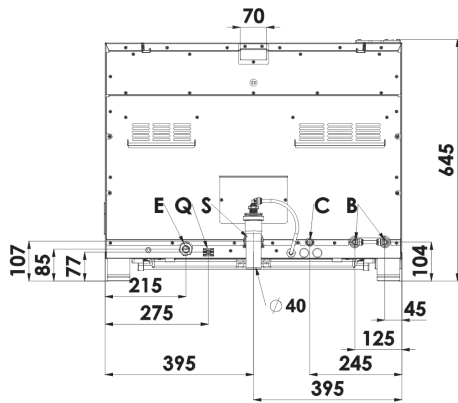

Q	EARTH TERMINAL
E	ELECTRICITY SUPPLY
S	WATER DRAIN TUBING
C	FILTER HOSE
B	BYPASS DESCALER